

LFT-PULTRUSION LINES

ProTec Polymer Processing

Pultrusion lines for the production of long-fiber reinforced thermoplastic (LFT) pellets

LFT pellets produced with ProTec production lines utilize best-in-class technology, resulting in superior material performance. We develop LFT-Pultrusion solutions that meet the latest technical challenges and your customers demanding requirements.



Innovative solutions in lightweight construction

We design and build Pultrusion lines that enable you to manufacture LFT pellets with wide range of polymer matrices and different fiber strengths. The Pultrusion process optimally coats the fiber strand in the impregnation tool for the production of LFT pellets for the manufacture of high strength and low

weight plastic parts. The advantages of LFT are becoming widely recognized, particularly in the automotive parts industry, and significant new applications are expected to develop in the packaging, appliances, sports equipment and facilities, medical and aerospace components.

Possible fiber-polymer combinations

Polymer	Abbreviation	Possible fibers in each polymer
Polypropylene	PP, also PP recycled	Glass, Carbon, Steel
Polyamide 6	PA6	Glass, Aramid, Carbon, Steel
Polyamide66	PA66	Glass, Aramid, Carbon, Steel
Alloy (polymer blend)	AY	Glass
Poly lactide (lactic acid)	PLA	Glass
Polyethylene	HDPE	Glass
Polycarbonate	PC	Glass, Steel
Acrylnitrile butadiene styrene	ABS	Glass, Steel
Polyphenylene oxide	PPO	Steel
Polyurethane	TPU	Glass, Carbon
Polyoximethylene/Polyacetal	POM	Glass, Aramid, Carbon, Steel
Polyester	PBT/PET	Glass
Polyphenylene sulfide	PPS	Glass, Aramid, Carbon, Steel

LFT-PULTRUSION LINES

ProTec Polymer Processing

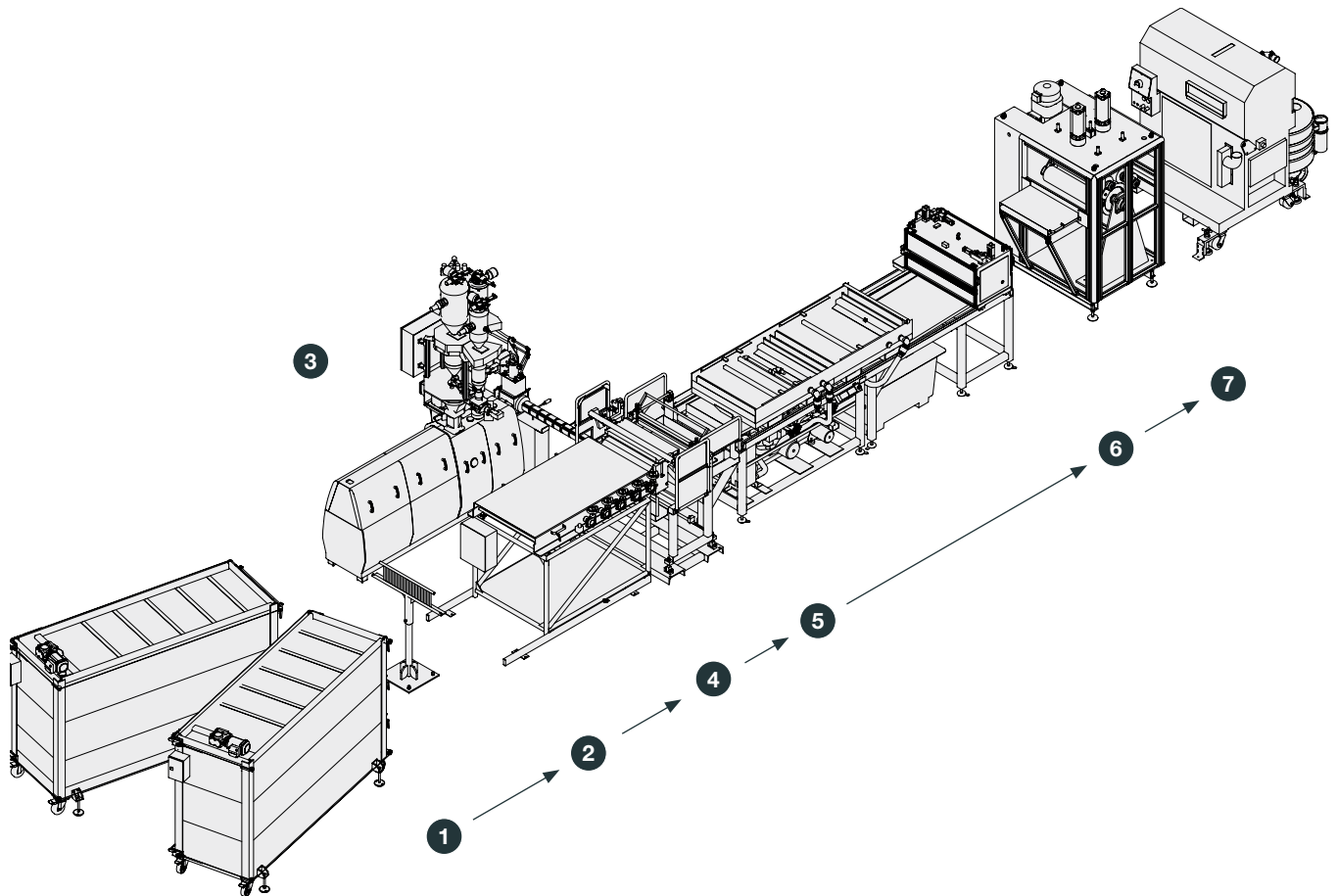

Highlights

- Standard & custom LFT lines
- High quality fiber impregnation
- Fully automated operation
- Runs different fiber & thermoplastic combinations
- Individual LFT formulation support
- Custom LFT sample pre-production
- Compatible with SOMOS® material handling equipment
- Technical support

Configuration for manufacturing LFT pellets

- 1 Creel rack for mounting and unwinding the fiber spools
- 2 Tensioner with combs for guiding and tensioning the fiber strands
- 3 Extruder for melt preparation
- 4 Tool for impregnating the fibers with the polymer melt
- 5 Cooling/water bath
- 6 Mechanism for tensioning and pulling the fiber-polymer strands (Puller)
- 7 Pelletizer

Are you interested in receiving additional information?
Then feel free to call us.

ProTec Polymer Processing GmbH
Stubenwald-Allee 9
64625 Bensheim
Germany

T+49 6251 77061-0
F+49 6251 77061-500
info@sp-protec.com
www.sp-protec.com